

OBI 40MM SPACER

SKU# 197062, 197063

NOTE: This installation instruction, is for the spacer accessory only.

Installation of this spacer accessory must be done by a licensed electrician.

This spacer accessory can only be used with the Obi luminaire SKU# 197060, 197061 (sold separately).

For the luminaire installation, refer to the included installation instructions with the luminaire.

Thank you for purchasing this quality MFL product. To ensure correct function and safety, please read and follow all instructions carefully before assembly, installation and use of this luminaire. Please keep instructions for future reference.

Warranty

- This accessory is covered by a 3-year warranty. The warranty is from the date of purchase, not the date of installation.
- If the accessory is not assembled and installed by a licensed electrician, the warranty will be void.
- Please retain the proof of purchase and evidence of installation by a licensed electrician for any warranty enquiries.
- Warranty will be void if there is any damage due to improper usage or modification to the accessory.
- Failure to comply with the instructions in this manual may increase the risk of damage or injury and will void the warranty.

Installation Requirements

- This accessory must be assembled and installed by a licensed electrician.
- This luminaire is a Class I product and must be earthed during the wiring and installation of this spacer accessory.
- Lay out all the components on a smooth surface and make sure no components are missing before assembling. If parts are missing, return the complete product to the place of purchase for inspection or replacement.
- Check whether the accessory has been damaged during transport. Do not operate/install any product which appears damaged in any way. Return the complete product to the place of purchase for inspection, repair or replacement.
- Ensure power to the circuit you are working on has been switched OFF before commencing any electrical work.

Installation Directions

1. Remove all packaging material from the product and be careful not to throw away accessories that may be hidden within the packaging material. If assembly is required, place it on a smooth non-scratch surface.
2. Remove the mounting bracket (C – not included) from both ends of the luminaire (A – not included) by loosening the grub screws (B – not included) on the sides with an Allen key.
3. Install the spacer (D) onto the luminaire (A – not included) and secure it by tightening the grub screws (B – not included).
4. Follow the installation instructions included with the luminaire to complete the installation.

NOTE: This luminaire is a Class I product and must be earthed during wiring and installation.

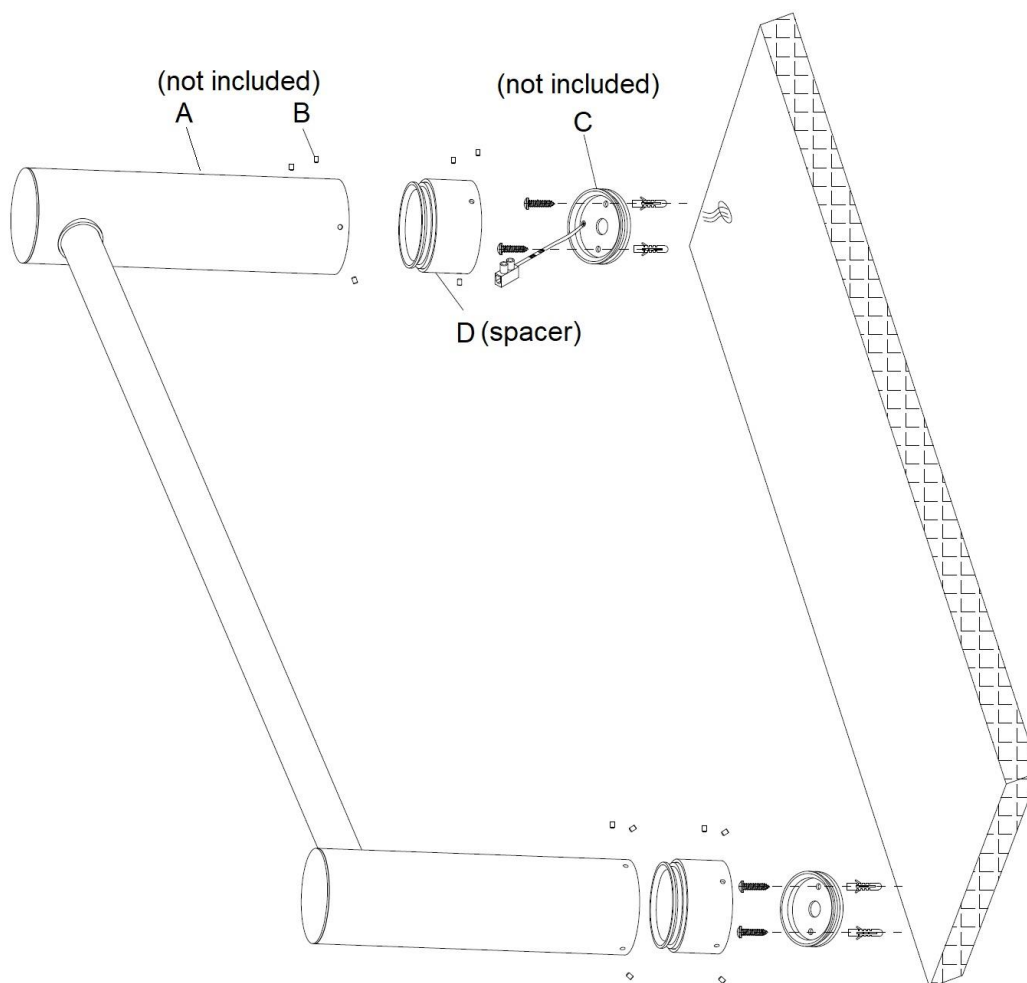

Safety Tips

- Always ensure the power is OFF and the luminaire has cooled down before performing any maintenance, cleaning or making any adjustment to the luminaire.
- To avoid injury or damage to the luminaire, ensure that power leads and screws are secure before connecting the power.
- Select a suitable location away from liquids and hazards.
- To clean, wipe with a soft damp cloth. Do NOT soak or immerse the luminaire in water or other liquids.
- Ensure that the luminaire does not come in contact with corrosive chemicals/solvents or abrasive cleaners etc.

Specifications

SKU#	197062	197063
Colours	Black	White
Weight	0.05kg	
Dimensions	H:40mm Dia:60mm	