

CALI 3 IN 1 BATHROOM HEATER, EXHAUST FAN & LIGHT

SKU# 209121

Rated Voltage 230-240V~ 50Hz

To ensure correct function and safety, please read and follow all instructions carefully before assembly, installation and use of this product. Please keep instructions for future reference.

Warranty

- This product is covered by a 3-year warranty. The warranty is from the date of purchase, not the date of installation.
- If the product is not assembled and installed by a licensed electrician, the warranty will be void.
- Please retain the proof of purchase and evidence of installation by a licensed electrician for any warranty enquiries.
- Warranty will be void if there is any damage due to improper usage or modification to the product.
- This product is not suitable for use with dimmer switches. Warranty will be void if this product is used on the same circuit which has a dimmer switch.
- Failure to comply with the instructions in this manual may increase the risk of damage or injury and will void the warranty.

Installation Requirements

- This product must be assembled and installed by a licensed electrician.
- All wiring and installation of the luminaire must adhere to the latest local and national wiring rules. e.g. AS/NZS 3000 Electrical Installations.
- An isolation switch must be included in the wiring installation. A circuit breaker can be classified as an isolation switch. The isolation switch allows disconnecting of the product and loads from the mains 240V AC power during maintenance and cleaning of the connected product and connected loads.
- This is a Class I product and must be earthed during wiring and installation.
- Do not exceed the maximum wattage rating.
- Select a suitable location for installation:
 - The mounting point must support 2 times the weight of the product.
 - This product is rated at IPX4. This must be maintained during wiring and installation of this product.
 - The unit can be installed in flat ceilings with a minimum height of 2 metres. At least 220mm height clearance in the ceiling cavity is required to ensure sufficient ventilation for moisture to disperse. The unit must also be installed at least 250mm away from the walls.
 - This product has an insulating ceiling type do-not-cover rating. This product can be used where normally flammable materials, including building insulation, are or may be present, but cannot be abutted against any material and cannot be covered in normal use. (Please refer to the Clearance Information section (page 3) and the do-not-cover rating section (page 4) in this instruction manual for further details.)
 - If loose fill insulation or thermal insulation is not fixed into position or if there are loose combustible materials (e.g. leaves or combustible materials stored in the roof space), a barrier or guard is required as per the Clearance Information section in this instruction manual.
 - Ensure adequate inlets exist through windows, vents or under the door for air flow.
- This appliance is not intended for use by persons (including children) with reduced physical, sensory or mental capabilities, or lack of experience and knowledge, unless they have been given supervision or instruction concerning use of the appliance by a person responsible for their safety.
- Children should be supervised to ensure that they do not play with the appliance.
- Lay out all the components on a smooth surface and make sure there are no components missing before assembling. If parts are missing, return the complete product to the place of purchase for inspection or replacement.
- Check whether the product has been damaged during transport. Do not operate/install any product which appears damaged in any way. Return the complete product to the place of purchase for inspection, repair or replacement.

Installation Directions

WARNING: Ensure power to the circuit you are working on has been switched OFF before commencing any electrical work.

1. Remove the heat globes and LED lamp from the lamp holders.
2. Remove the fascia from the body by loosening the spring hooks from the holes of the fascia.
3. The unit may be mounted either between joists using the in-built clip fasteners.

Use this card in its open state as a template. Place in the required location and mark the cut-out hole. Please refer to the specifications table (Page 4) for the cut-out size.

NOTE: Before cutting, ensure that the area behind the intended location is clear of all cables, pipes and joists. Ensure all the clearance values (see page 3 & 4) are maintained during and after installation of the product, thermal insulation, loose fill insulation, loose combustible materials and any structural members.

Once clear, cut out the section along the previously marked lines. (Fig. A).

4. Connect the mains supply wire to the product. See the wiring section (Page 3) for more information. (Fig. B)
5. Install the duct cover on the wall; make sure the blind shutters facing down.
6. Install the vent duct to exhaust hole on the fan body and fix it by a tie cable.
7. Install the other end of vent duct to duct cover and fix it by a tie cable.
8. Insert the unit into the cut-out hole, ensuring to pull the side springs inward so that the body can pass through the hole without damaging the plaster. Use the four clips to fix to the housing. Ensure that the unit is held securely in place by the clips. (Fig. C)
9. Hold the fascia against the body of the unit and attach the spring clips to hold the fascia in place. (Fig. D).
10. Install the heat globes and LED lamp into the lamp holders. The globes should be screwed up firmly to ensure a good electrical contact but don't over tighten. Next fit the small centre globe in the same way ensuring that it is positioned centrally. (Fig. D & E & F).

Fig. A

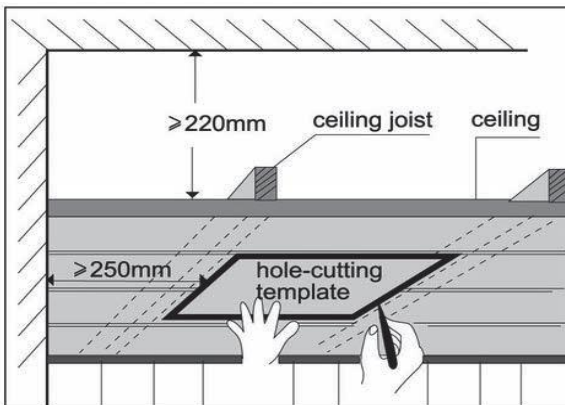

Fig. B

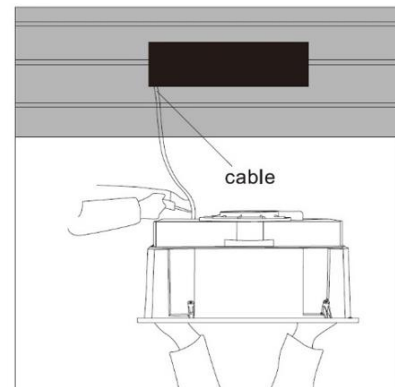

Fig. C

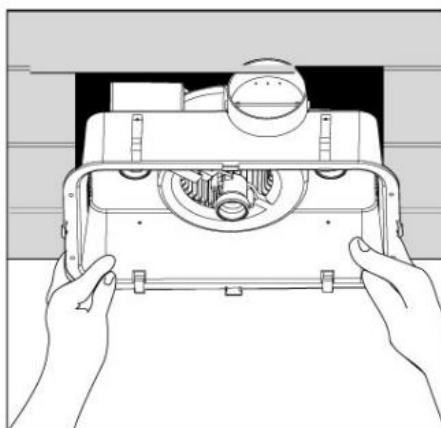
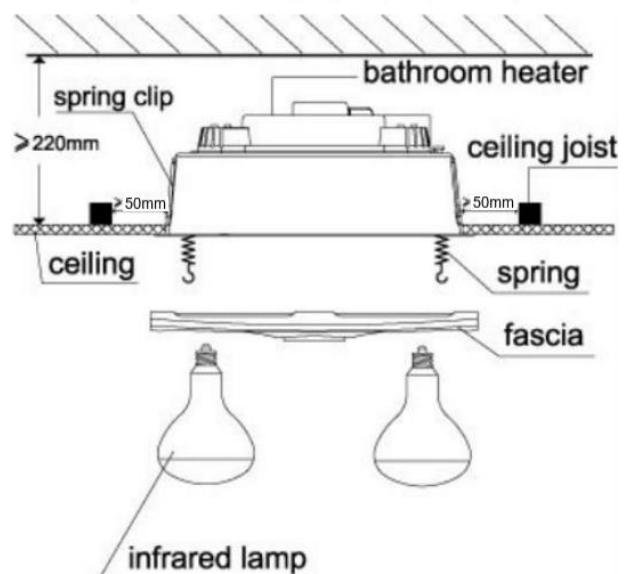

Fig. D



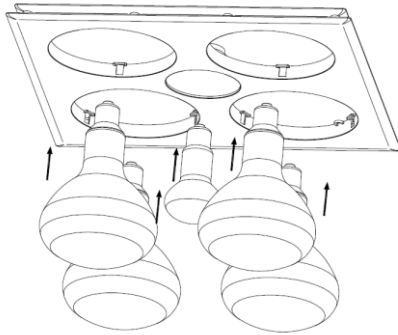

Fig. E

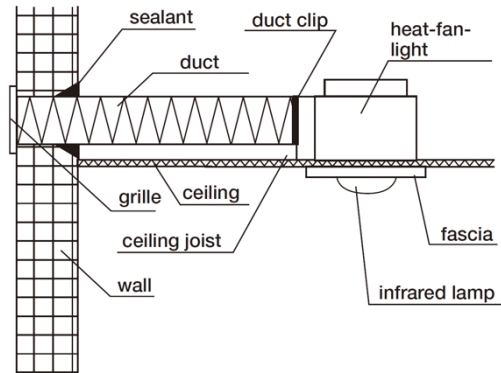

Fig. F

Wiring

NOTE: An isolation switch must be included in the wiring installation. A circuit breaker can be classified as an isolation switch. The isolation switch allows disconnecting of the product and loads from the mains 240V AC power during maintenance and cleaning of the connected product and connected loads.

- Remove the terminal cover on the fan body by loosening the screws and wire according to the label adjacent to the terminal block. Make sure all cables are securely connected and reinstall the terminal cover.
- Connect the wiring to the switches as shown in the below electrical diagram.
- Install the plate of wall switch on the wall.

NOTE: This is a Class I product, and must be earthed during wiring and installation.

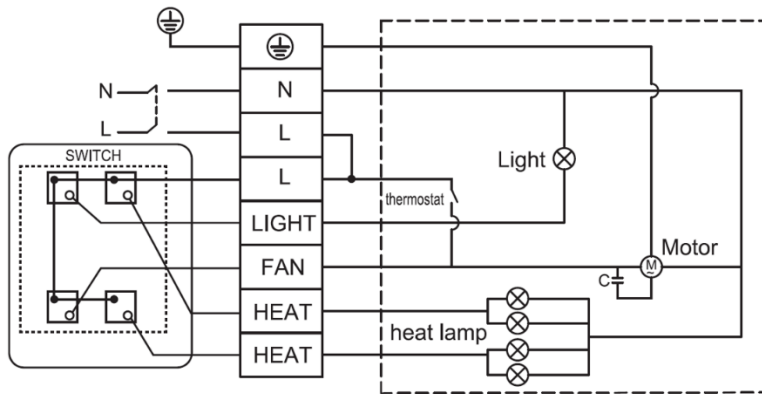

Clearance Information – AS/NZS 3000 Wiring Rules - Figure 4.9

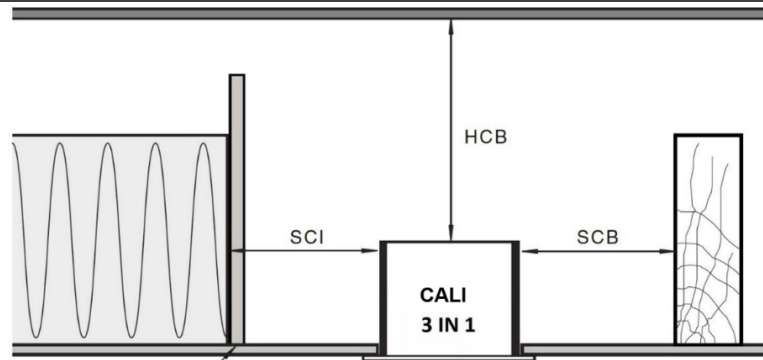

FIXED GUARD REQUIRED WHERE:-
 • insulation materials are not secured in position;
 • loose materials are present.

NOTE: If loose fill insulation or thermal insulation is not fixed into position or if there are loose combustible materials (e.g. leaves or combustible materials stored in the roof space), a barrier or guard is required.

LOCATION	DISTANCE	DESCRIPTION
HCB	15mm (Minimum)	Clearance between the top of the product and any structural members, building elements or objects above it.

SCB	50mm (Minimum)	Clearance between the side of the product and any structural members, building elements or objects.
SCI	50mm (Minimum)	Insulation cannot be abutted against the side of the product and cannot be covered in normal use.

Do-not-cover Rating – AS/NZS 60598.2.2 : 2016

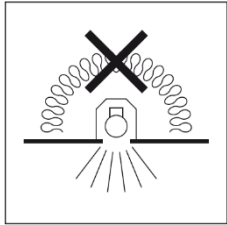

This product can be used where normally flammable materials, including building insulation, are or may be present, but cannot be abutted against any material and cannot be covered in normal use.

RISK OF FIRE – BUILDING INSULATION MUST NOT COVER THIS LUMINAIRE

HCB = 15 mm

SCB = 50 mm

SCI = 50 mm

Safety Tips

NOTE: Always ensure the power is switched OFF from the isolation switch/mains before performing any maintenance cleaning or making any adjustment to the product.

- The supplied LED lamp is NOT dimmable. DO NOT connect the LED lamp with dimming circuits.
- To avoid injury or damage to the luminaire, ensure that power leads and screws are secure before connecting the power.
- To clean, wipe with a soft damp cloth. Do NOT soak or immerse the luminaire in water or other liquids.
- Ensure that the luminaire does not come in contact with corrosive chemicals/solvents or abrasive cleaners etc

Specifications

SKU #	209121
Colour	White
Rated Voltage	230-240V~ 50Hz
Total Rated Power	1143W
Exhaust Fan - Rated Wattage	35W
Heat Globe - Rated Wattage	1100W Max. (4x Max. 275W) ES, R125, (Reflector type globe included)
LED lamp - Rated Wattage	8W Max. ES, R63 (Cool White 4000K LED globe included)
Cut Out Size	320mm x 320mm
Exhaust Fan Duct Diameter	Ø 125mm
IP Rating	IPX4
Luminaire Rating	Do-not-cover
Dimensions	H:275mm W:420mm L:370mm
Weight	3.98kg

LUCCI

BATHROOM HEATER WARRANTY CARD

Every Lucci Air Cali 3 in 1 Bathroom Heater, Exhaust Fan & Light is thoroughly inspected and tested before being released for sale. In addition to any warranties or conditions implied by applicable Statute or Regulation, Lucci Design warrants all of its bathroom heaters against defective workmanship and faulty materials for thirty six (36) months from the original date of purchase. Lucci Design undertakes, at its option, to repair or replace, free of charge, each product or part thereof subject to the below warranty conditions;

- 1) The fan or relevant part has not been modified, subjected to misuse, neglect, or been involved in an accident.
- 2) The repairs are not required as a result of normal wear and tear.
- 3) The product was installed by a licenced electrical contractor in accordance with this instruction manual.
- 4) No solid state speed control device has been used with the appliance.
- 5) A copy of the original receipt of purchase is presented.
- 6) Globes supplied are not covered by this warranty

Lucci Design cannot be held responsible for any repair other than those carried out by it or one of its Authorised Service Agents. Please keep this warranty card in a safe place. This card must be produced in the event of service being required.

IN THE EVENT OF SERVICE BEING REQUIRED, PLEASE CALL
THE LUCCI FAN WARRANTY HOTLINE ON 1800 602 243 BETWEEN
9AM & 5PM (E.S.T) MONDAY TO FRIDAY ENSURING THAT YOU
HAVE THE FOLLOWING DETAILS ON HAND:

MODEL (SKU) NUMBER: _____

DATE OF PURCHASE: _____

RETAILER: _____

RECEIPT NUMBER: _____

INSTALLED BY: _____

LICENCE #: _____ PH: _____

DESCRIPTION OF FAULT: _____
