

## Sentinel Step Light

SKU# 220396, 220397, 220398, 220399

Rated Voltage 12V

Thank you for purchasing this quality Lucci product. To ensure correct function and safety, please read and follow all instructions carefully before using the product. Please keep instructions for future reference.

### Warranty

- This light fitting is covered by a 12 month warranty. Please retain proof of purchase and evidence of installation by a licensed electrician.
- Warranty will be void if there is any damage due to improper usage or modification to the fitting.

### Installation requirements

- Must be installed by a licensed electrician.
- All wiring and installation of the light fitting must adhere to local and national wiring rules. eg. AS/NZS 3000:2007/Amendment 2:2012 Electrical installations.
- Do not exceed the maximum wattage rating.
- This fitting is rated IP44. This must be maintained during installation.
- Replace any cracked protective lamp shape to maintain IP rating when using this fitting.
- Select a suitable location for installation;
  - This product is suitable for indoor and outdoor use.
  - The mounting point must support 2 times the weight of the fitting.
- Take care not to pull any electrical wires during unpacking as this may damage the connection.
- Lay out all the components on a smooth surface and make sure there are no components missing before assembling.
- Check whether the fitting has been damaged during transport. Do not operate/install any product which appears damaged in any way. Return the complete product to the place of purchase for inspection, repair or replacement.
- Ensure power to the circuit you are working on has been switched OFF.

### Installation directions

1. Loosen the screws to take off the lamp base. Fig. 1
2. Using the lamp base as a template, mark and drill holes into the wall and hammer in anchors. Secure the lamp base on the wall via tightening the screws with rubber washers. Fig. 2
3. Install the bulb (not included). Fig. 3
4. Connect the main 12V leads to the transformer (not included). Fig. 4
5. Secure the lamp cover on the lamp base via tightening the screws with rubber washers. Fig. 4

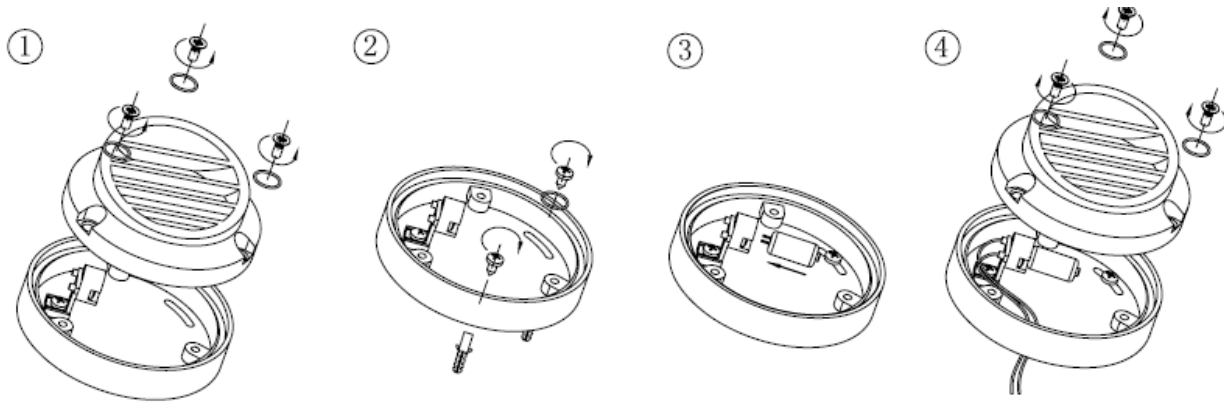

## Safety tips

- Always ensure the power is OFF and the fitting has cooled down before performing any maintenance, cleaning, changing the globe or adjustment to the fitting.
- Do not touch the globe with bare hands. Use a clean cloth, gloves or a tissue.
- To avoid injury or damage to the fitting, ensure that power leads and screws are secure before connecting the power.
- Select a suitable location away from hazards.
- Ensure that the fitting does not come in contact with corrosive chemicals, etc.
- To clean, wipe with a damp clean cloth. Never soak the fitting with water.

## Specifications

SKU #	220396	220397	220398	220399
Model #	LD-7471-ST#304	LD-7471-ST#316	LD-7472-ST#304	LD-7472-ST#316
Rated Voltage	12V			
Rated Wattage	12V, 1 X 20W MAX			
Lamp Holder	G5.3			
Weight	0.86kg		0.58kg	
IP Rating	IP44			
Dimensions	H:48mm Dia:101mm			