

SEASIDE ESCARPMENT WALL SCONE

SKU# 238007, 238012

Rated Voltage 220-240V~ 50Hz

To ensure correct function and safety, please read and follow all instructions carefully before assembly, installation and use of this luminaire. Please keep instructions for future reference.

Warranty

- This luminaire is covered by a 5-year warranty. The warranty is from date of purchase, not the date of installation.
- If the luminaire is not assembled and installed by a licensed electrician, the warranty will be void.
- Please retain the proof of purchase and evidence of installation by a licensed electrician for any warranty enquiries.
- Warranty will be void if there is any damage due to improper usage or modification to the luminaire.
- Failure to comply with the instructions in this manual may increase the risk of damage or injury and will void the warranty.

Installation Requirements

- This luminaire must be assembled and installed by a licensed electrician.
- All wiring and installation of the luminaire must adhere to the latest local and national wiring rules. E.g. AS/NZS 3000 Electrical Installations.
- This luminaire is a Class I product and must be earthed during wiring and installation.
- This luminaire is rated IP65, this must be maintained during wiring and installation
- This luminaire is suitable for use with LED lamp only .Do not exceed the maximum wattage rating.
- Select a suitable location for installation:
 - This luminaire is suitable for wall mount only, please follow the directional label during installation.
 - The mounting point must support 2 times the weight of the luminaire.
 - This luminaire is protected against water penetration to IP65 standards, which is against low-pressure jets of water from all practicable directions.
- Take care not to pull any electrical wires during unpacking as this may damage the connection.
- Lay out all the components on a smooth surface and make sure no components are missing before assembling. If parts are missing, return the complete product to the place of purchase for inspection or replacement.
- Check whether the luminaire has been damaged during transport. Do not operate/install any product which appears damaged in any way. Return the complete product to the place of purchase for inspection, repair or replacement.
- Ensure power to the circuit you are working on has been switched OFF before commencing any electrical work.

Installation Directions

1. Remove all packaging material from the product and be careful not to throw away accessories that may be hidden within the packaging material.
2. Remove the base plate (J) from the luminaire (F) by loosening the screws (K).
3. Remove the shade (I) from the luminaire (F) by twisting it anti-clockwise.
4. Remove the mounting bracket (B) from the luminaire (F) by loosening the screws (E).
5. Use the mounting bracket (B) as a template to mark the screw hole positions on the wall.

NOTE: This luminaire is suitable for wall mount only, please follow the directional label during installation.

6. Install the mounting bracket (B) onto the wall by using appropriately sized mounting screws (C) and anchors (A). Ensure the screws (C) and anchors (A) used are suitable for the mounting surface and the surrounding environment.

7. Connect the mains supply wire to the connector (D). Ensure the wires are secure and no bare wires are exposed.

Mains Supply Wire

Earth – Yellow/Green 

Neutral – Blue or Black

Live – Brown or Red

Luminaire Wire / Terminal label

Yellow/Green or 

Blue or N

Brown or L

NOTE: This luminaire is a Class I product and must be earthed during wiring and installation.

NOTE: This gland is only suitable for H05RN-F type/size cable.

8. Install the luminaire (F) onto the mounting bracket (B) and secure by tightening the screws (E).

9. Install a LED lamp (H - not included) into the lamp holder (G). Do not exceed the maximum wattage rating.

NOTE: This luminaire is suitable for use with LED lamp only.

10. Install the shade (I) back to the luminaire (F) by twisting it clockwise.

NOTE: This luminaire is rated IP65, this must be maintained during wiring and installation.

NOTE: Ensure the washer is flat and is not deformed to maintain the IP65 rating.

11. Install the base plate (J) back to the luminaire (F) by tightening the screws (K).

12. After the installation, switch on the luminaire to test all the lighting functions and enjoy your new luminaire.

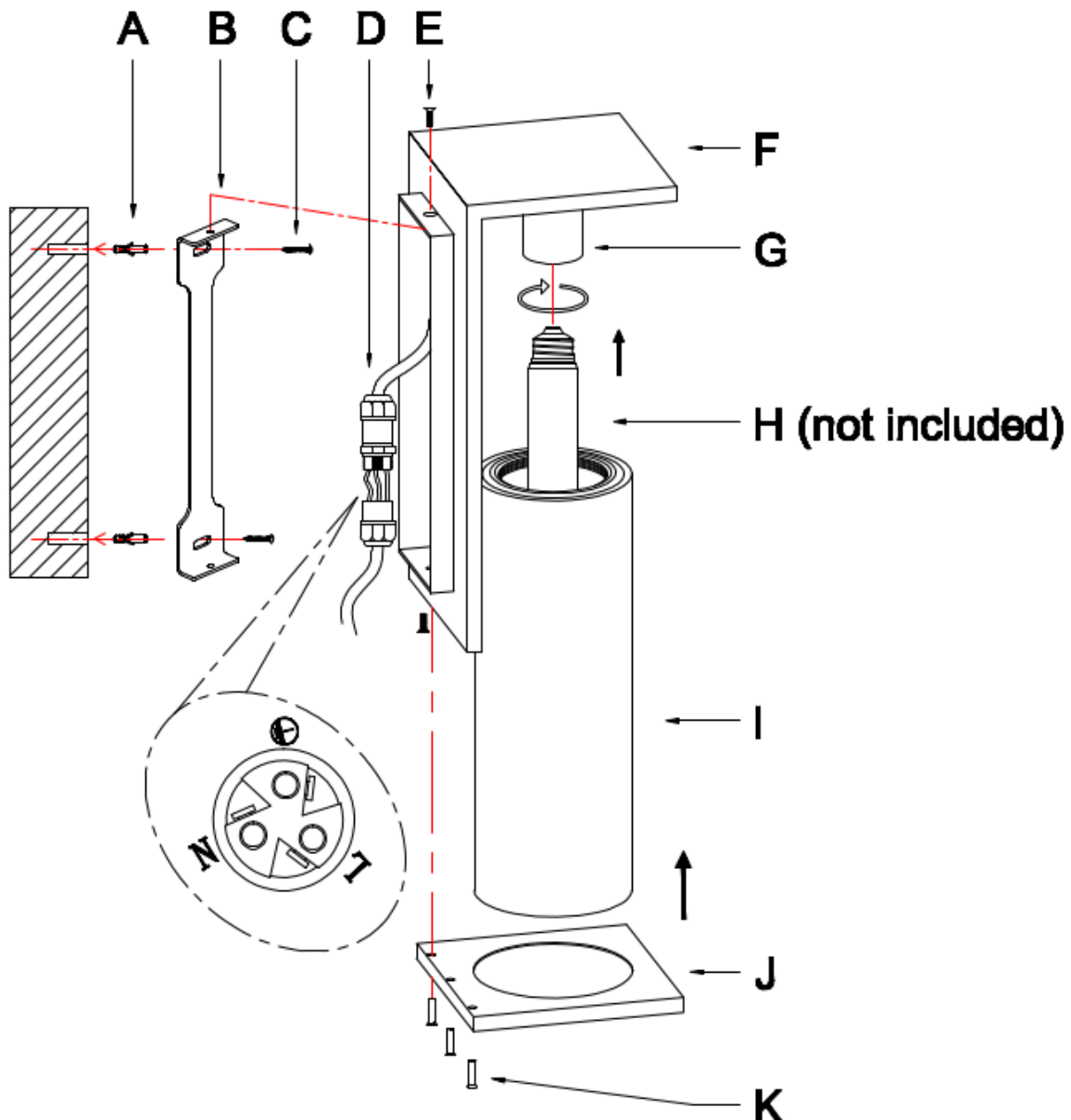

Safety Tips

- Always ensure the power is OFF and the luminaire has cooled down before performing any maintenance, cleaning, changing the globe or making any adjustment to the luminaire.
- To avoid injury or damage to the luminaire, ensure that power leads and screws are secure before connecting the power.
- To clean, wipe with a soft damp cloth. Do NOT soak or immerse the luminaire in water or other liquids.
- Ensure that the luminaire does not come in contact with corrosive chemicals/solvents or abrasive cleaners etc.

Specifications

SKU #	238007	238012
Colour	Aged Solid Bronze	Solid Brass
Rated Voltage	220-240V~ 50Hz	
Rated Wattage	15W Max. (LED lamp only)	
Lamp Holder	ES/E27	
IP Rating	IP65	
Weight	4.2kg	
Dimensions	H:300mm W:140mm E:155mm	