

Installation Instructions
SKU# 240204 (LD-RS8CE)
(Ceiling PIR Sensor)
Rated Voltage 220-240V~ 50Hz

THANK YOU FOR PURCHASING THIS QUALITY LUCCI PRODUCT, TO ENSURE CORRECT FUNCTION AND SAFETY, PLEASE READ AND SAVE ALL INSTRUCTIONS CAREFULLY BEFORE USING THE PRODUCT.

WARRANTY:

- This sensor is covered by a 12 month warranty; please retain proof of purchase and evidence of installation by a licensed electrician.
- Warranty will be void if there is any damage due to improper usage or modification to the sensor.
- Warranty will be void if the lens cover is removed, as this will damage the sensor.
- The sensor is not suitable for use with dimmer switches.
Warranty will be void if the sensor is used on the same circuit which has a dimmer switch.
- There are no serviceable parts inside the sensor.

INSTALLATION REQUIREMENTS:

- **Must be installed by a Licensed Electrician.**
- **All wiring & installation of the sensor must adhere to local and national wiring codes. AS/NZS 3000 latest edition.**
- **This sensor is rated IP44 when fully installed, this must be maintained during installation. (please note the back of the sensor is rated IP20)**
- **Select a suitable location for installation. This sensor is protected against water penetration to IP44 standards, which is water splashing in every direction.**
- **The sensor is not suitable to use with dimmer switches and should not be used with a circuit which has a dimmer.**
- **The rated load for the sensor depends on the lamp type used;**
Incandescent Lamps Max. 2000W
Fluorescent Lamps Max. 600W
LED Lamps Max. 200W
- **Take care not to pull any electrical wires during unpacking as this may damage the connection.**
- **Lay out all the components on a smooth surface and make sure there is no component's missing before assembling.**
- **Check whether the sensor has been damaged during transport. Do not operate/install any product which appears damaged in any way. Return the complete product to the place of purchase for inspection, repair or replacement.**
- **Ensure all power to the circuit you are working on has been switched OFF.**

PIR (PASSIVE INFRA RED) INTRODUCTION:

This unit has a PIR (Passive Infra Red) sensor which continuously scans the operating zone and will send a load when it detects movement in that area. Whenever movement is detected within the range of the sensor, it will send a load to the light (not included) to switch on and automatically illuminate the area. While there is movement within the sensor range, the light (not included) will remain on.

SENSOR INFORMATION:

To find a suitable location for installation, please take into consideration the following points:

- The maximum detection height for the sensor is 2.8m (Figure 1).
- The detection area is approximately 4.5m away (9m diameter) at an angle of 360°. This may vary depending on the mounting height and location.
- The detection area may also alter at different temperatures. PIR sensors are more sensitive in cold weather than warm weather.
- The sensor has increased sensitivity with movement across the detection area (Figure 2A).
- The sensor has reduced sensitivity with movement towards and away from the detection area (Figure 2B).
- If movement is made walking directly towards or away from the sensor and not across, the apparent detection range will be substantially reduced.
- To avoid nuisance triggering, the sensor should be directed away from potential heat sources such as barbecues, air-conditioners, air vents etc.
- Also avoid areas with electromagnetic disturbance, outside lighting, moving cars, trees or pets etc.
- Avoid installing the fitting in close proximity or on the same circuit to any fluorescent light fittings or ceiling fans. RFI (Radio Frequency Interference) may cause the fitting to switch on unintentionally.
- Do not aim the sensor towards reflective surfaces, such as smooth white walls, swimming pools etc.
- To avoid damage to the sensor, do not aim the sensor towards the sun.
- It is recommended that the fitting is installed on its own switch and does not interconnect with other lights on the same switch as it may cause nuisance triggering.
- The sensor is not suitable to use with dimmer switches and should not be used with a circuit which has a dimmer.

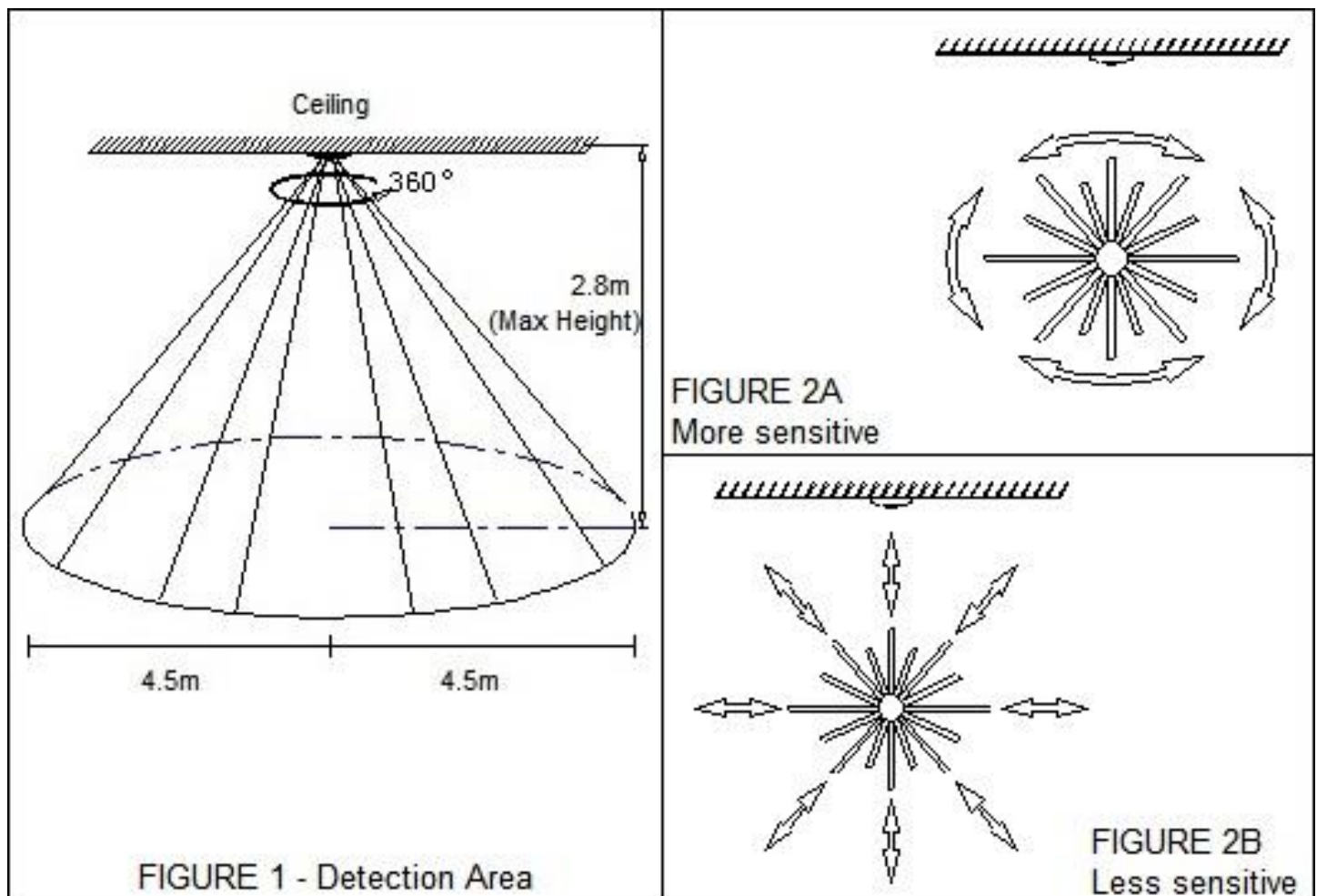

INSTALLATION DIRECTIONS:

1. Cut an installation hole of $\text{Ø}63\text{mm}$ into the ceiling.
2. Remove the terminal cover (figure 3, part A) from the sensor.
3. Loosen the screws at the terminal and connect the mains supply wires and load wires to the sensor.
4. Ensure that the wires are secure and no bare wires are exposed. Use the cord anchorage (figure 3, part B) to hold the wires in position and place the terminal cover (figure 3, part A) firmly back over the terminals.
5. Push the springs up and push the sensor up through the cut-out hole and into the ceiling (figure 4).

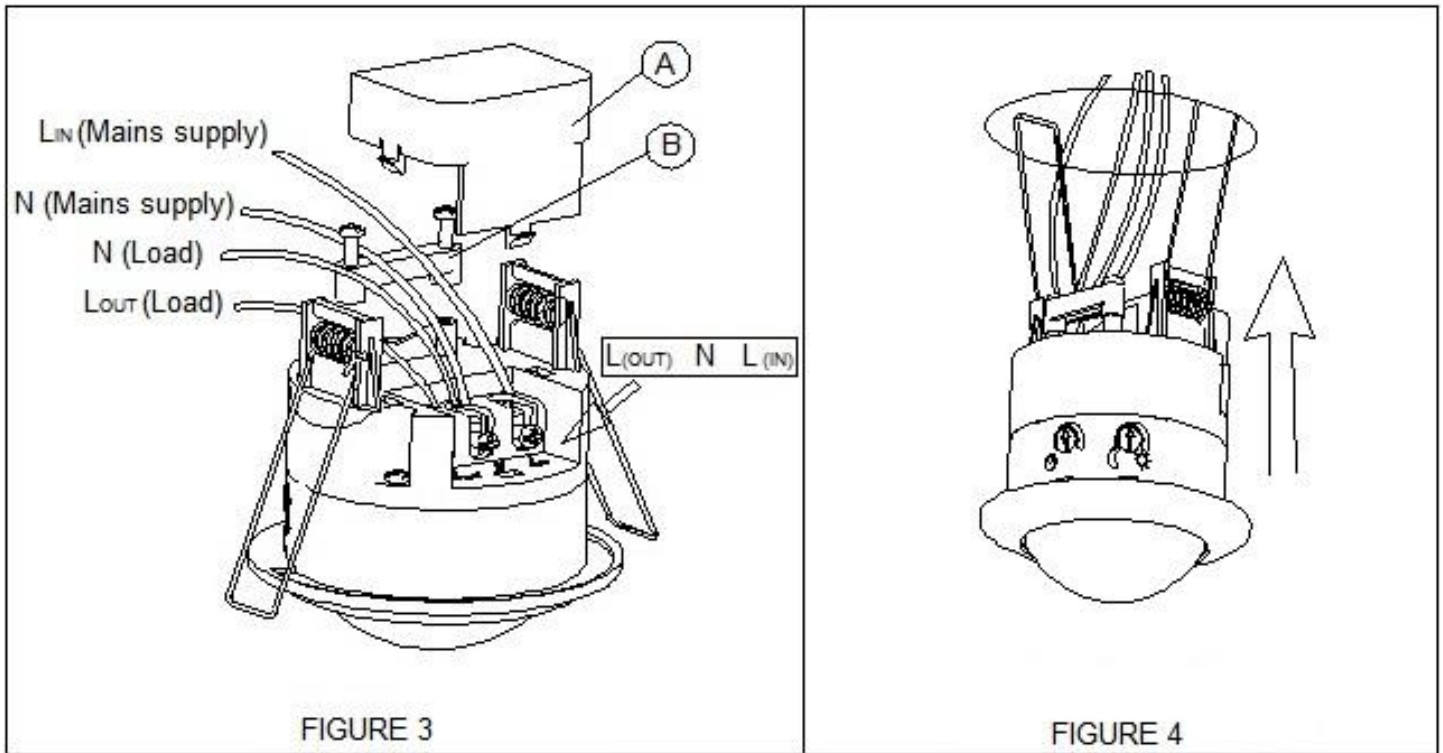

SENSOR SETTINGS:

TIME: The length of time that the sensor switches the load 'on' after activation.

The duration time can be adjusted from a minimum of 10secs ± 5 to a maximum of 4mins ± 1 .

Rotating the time from (+) to (-) will reduce the duration time.

NOTE: Once the light has been triggered by the PIR sensor, any subsequent detection will start the timed period again from the beginning until there is no movement detected.

LUX: The lux control module has a built-in sensing device (photocell) that detects daylight and darkness.

The (*) position means that the sensor will work at both day and night.

The (D) position will only work at night.

NOTE: If you want to test the detection area of the PIR sensor, please wait for the ambient light level is below 20 lux.

SENSOR TESTING AND SETUP:

1. After the sensor has been installed and there is power to the sensor, it will enter a “WARM UP” period for about 30 seconds (within 1 minute). After this “WARM UP” period it will switch to “AUTO MODE” and you can begin the sensor testing and setup.
2. Put the LUX control knob to the day light (☀) position and the TIME control knob to minimum (-).
3. When the sensor detects movement in the detection area, it will send a load to the the light (not included) and it will be turned on for the pre-set time.
4. Have someone slowly walk across the sensor to determine the detection area.
5. Adjust the TIME control knob to the desired length of time for the light to remain on.
6. Adjust the LUX control knob to achieve the ideal ambient light for the light to switch on.
For the light to switch ‘on’ when the ambient light is darker switch the LUX control knob from (☀) to (☾).
For the light to switch ‘on’ when the ambient light is brighter switch the LUX control knob from (☾) to (☀)
You may need to make further adjustments to achieve your ideal light level setting.

SAFETY TIPS:

1. Always ensure the power is OFF before performing any maintenance or adjustment to the sensor.
2. To avoid injury or damage to the sensor, ensure that power leads and screws are secure before connecting the power.
3. Find a suitable location away from liquids and hazards.
4. Ensure that the sensor does not come in contact with corrosive chemicals or harsh cleaning products etc.
5. To clean, wipe with a damp clean cloth. Never soak the sensor with water.

SPECIFICATIONS:

SKU #	240204
MODEL #	LD-RS8CE
RATED VOLTAGE	220-240V~ 50Hz
RATED WATTAGE	Max. 2000W for Incandescent Lamps Max. 600W for Fluorescent Lamps Max. 200W for LED Lamps
CUT-OUT SIZE	63mm
DIMENSIONS	76mm x 76mm (D x H)
IP RATING	IP44