

WANAKA UP/DOWN WALL LIGHT WITH SENSOR

SKU# 246112

Rated Voltage 220-240V~ 50Hz

Thank you for purchasing this quality Lucci product. To ensure correct function and safety, please read and follow all instructions carefully before assembly, installation and use of this product. Please keep instructions for future reference.

Warranty

- This luminaire is covered by a 5-year warranty. The warranty is from the date of purchase, not the date of installation.
- If the luminaire is not assembled and installed by a licensed electrician, the warranty will be void.
- Please retain the proof of purchase and evidence of installation by a licensed electrician for any warranty enquiries.
- Warranty will be void if there is any damage due to improper usage or modification to the luminaire.
- This luminaire is not suitable for use with dimmer switches. Warranty will be void if the luminaire is used on the same circuit, which has a dimmer switch.
- Failure to comply with the instructions in this manual may increase the risk of damage or injury and will void the warranty.

Installation Requirements

- This luminaire must be assembled and installed by a licensed electrician.
- All wiring and installation of the luminaire must adhere to the latest local and national wiring rules. E.g. AS/NZS 3000 Electrical Installations.
- This luminaire is a Class II product, this must be maintained during wiring and installation of the luminaire.
- Do not exceed the maximum wattage rating.
- Select a suitable location for installation:
 - The mounting point must be able to support 2 times the weight of the luminaire.
 - This luminaire is protected against water penetration to IP44 standards, which is water splashing from any direction. The IP44 rating must be maintained during wiring and installation of the luminaire.
 - It is recommended the luminaire is installed on its own switch and not interconnected with other luminaires on the same switch, as it may cause the luminaire to switch on unintentionally.
 - Avoid installing the luminaire in close proximity or on the same circuit to any fluorescent luminaires or ceiling fans. RFI interference may cause the luminaire to switch on unintentionally.
 - See the **Sensor Information** section in this instruction manual for additional information about the sensor detection range and sensitivity, to select a suitable installation location
- The luminaire is not suitable to use with dimmer switches and must not be used with a circuit which has a dimmer.
- The luminaire must not be used if the protective shield or shade has been cracked or damaged. Replace the protective shield or shade before using the luminaire.
- Take care not to pull any electrical wires during unpacking as this may damage the connection.
- Lay out all the components on a smooth surface and make sure there are no components missing before assembling. If parts are missing, return the complete product to the place of purchase for inspection or replacement.
- Check whether the luminaire has been damaged during transport. Do not operate/install any product which appears damaged in any way. Return the complete product to the place of purchase for inspection, repair or replacement.
- Ensure power to the circuit you are working on has been switched OFF before commencing any electrical work.

Sensor Information

PIR (PASSIVE INFRA-RED) SENSOR:

The luminaire has a PIR (Passive Infra-Red) sensing device which continuously scans the operating zone and immediately switches the luminaire on when it detects any movement in that area. Whenever movement is detected within the sensor range, the luminaire will switch on automatically to illuminate the area.

NOTE: While there is movement within the sensor range, the luminaire will remain on.

SENSOR LOCATION & DETECTION:

- The ideal mounting height is between 1.5m – 2.0m (Fig. A)
- The maximum detection area is approximately 10m away with an angle of 110°. The detection area will vary depending on the mounting height and items in the detection area. (Fig. A)
- The sensor has increased sensitivity with movement across the detection area. (Fig. B)
- The sensor has reduced sensitivity with movement towards and away from the detection area. (Fig. C)
- If movement is made walking directly towards or away from the sensor and not across its detection area, the detection range will be substantially reduced.
- The detection area may also alter at different temperatures.
- To avoid damage to the sensor, do not aim the sensor towards the sun.
- To avoid false triggering:
 - The sensor should be directed away from potential heat sources such as air conditioners, exhaust vents etc.
 - Avoid areas with strong electromagnetic disturbance, outside lighting, moving cars, trees, pets etc.
 - Do not aim towards reflective surfaces, such as smooth white walls, swimming pools, ponds etc.
 - It is recommended the luminaire is installed on its own switch and not interconnected with other luminaires on the same switch.
 - Avoid installing the luminaire in close proximity or on the same circuit to any fluorescent luminaires or ceiling fans. RFI interference may cause the luminaire to switch on unintentionally.

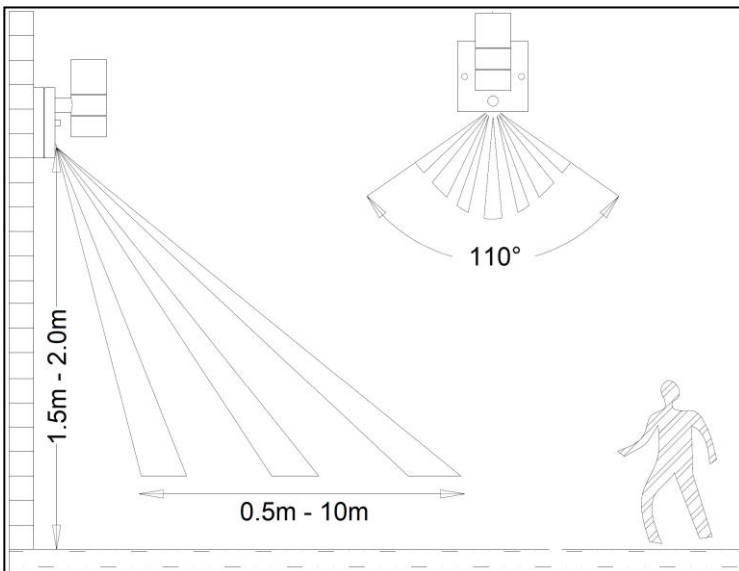

Fig. A (not to scale)

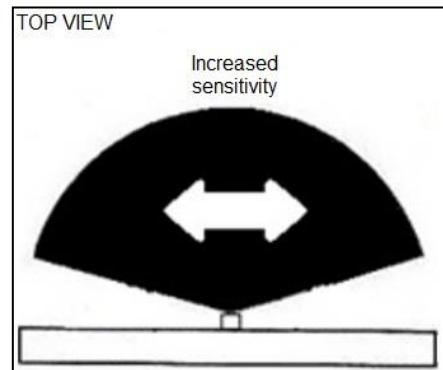

Fig. B

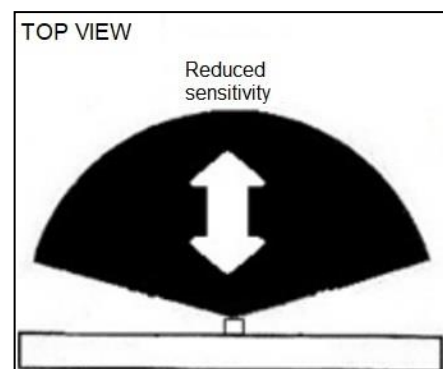

Fig. C

Installation Directions

1. Remove all packaging material from the product and be careful not to throw away accessories that may be hidden within the packaging material. If assembly is required, place the luminaire on a smooth non-scratch surface.
2. Ensure power to the circuit you are working on has been switched OFF before commencing any electrical work. (Fig. 1)
3. Remove the back plate from the luminaire by loosening the nuts and washers from the front of the luminaire.

NOTE: Keep the nuts and washers in a safe location, they are required for installation later.

4. Use the back plate as a template to mark the screw positions on the wall. (Fig. 1)
5. Install the back plate on the wall by using appropriately sized mounting screws and anchors. Ensure the mounting screws and anchors used are suitable for the mounting surface and the surrounding environment. (Fig. 2)

NOTE: A non-corrosive bead of silicon MUST be applied before installation onto the wall ensuring that no water can run down into the cabling or the mounting screws.

NOTE: Follow the mounting direction on the back plate.

NOTE: This luminaire is a Class II product and must be maintained during wiring and installation.

6. Slide the heat shrink tube over the terminal block and onto the luminaire wires (Fig. A)
7. Connect the mains supply wire to the terminal block. (Fig. B)

Mains Supply Wire	Luminaire Wire / Terminal label
Neutral – Blue or Black	Blue or N
Live – Brown or Red	Brown or L

8. Ensure the wires are secure and no bare wires are exposed. (Fig. C)
9. Slide the heat shrink tube over the terminal block so it covers both sides of the terminal block. (Fig. D)
10. Apply heat to the tube until it is tightly secured to the terminal block and wires. (Fig. D)

NOTE: THE INSTALLING ELECTRICIAN MUST ENSURE THE SUPPLY WIRE MAINTAINS DOUBLE INSULATION AFTER CONNECTING TO THE TERMINAL BLOCK.

11. Install the luminaire onto the back plate and secure using the washer and nuts. (Fig. 3)
12. Install LED globes (not included) into the lamp holders and install the shades back onto the luminaire. (Fig. 4)
13. Do not exceed the maximum wattage rating. This luminaire is suitable for use with LED globes only.
14. Check that all parts are done up tightly before turning on. (Fig. 5)
15. Switch on the luminaire to test and enjoy your new lighting product. (Fig. 6)

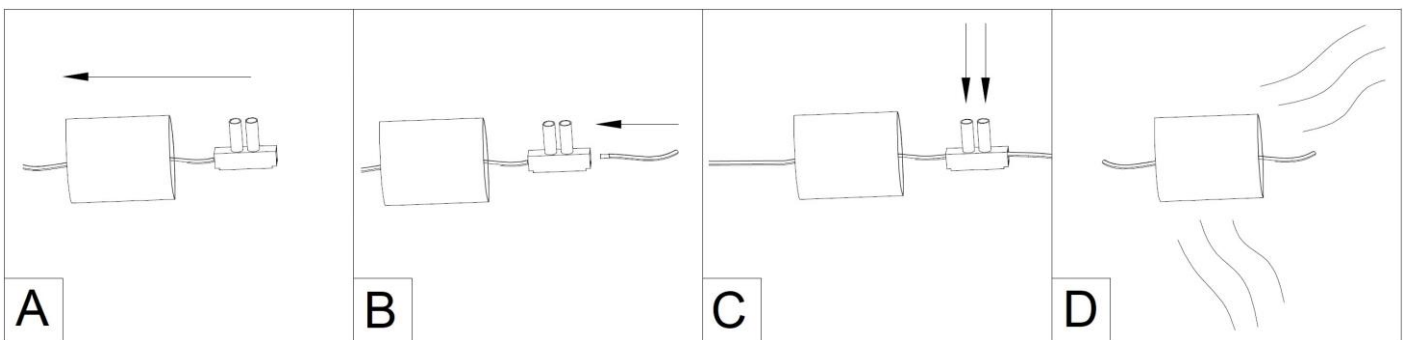
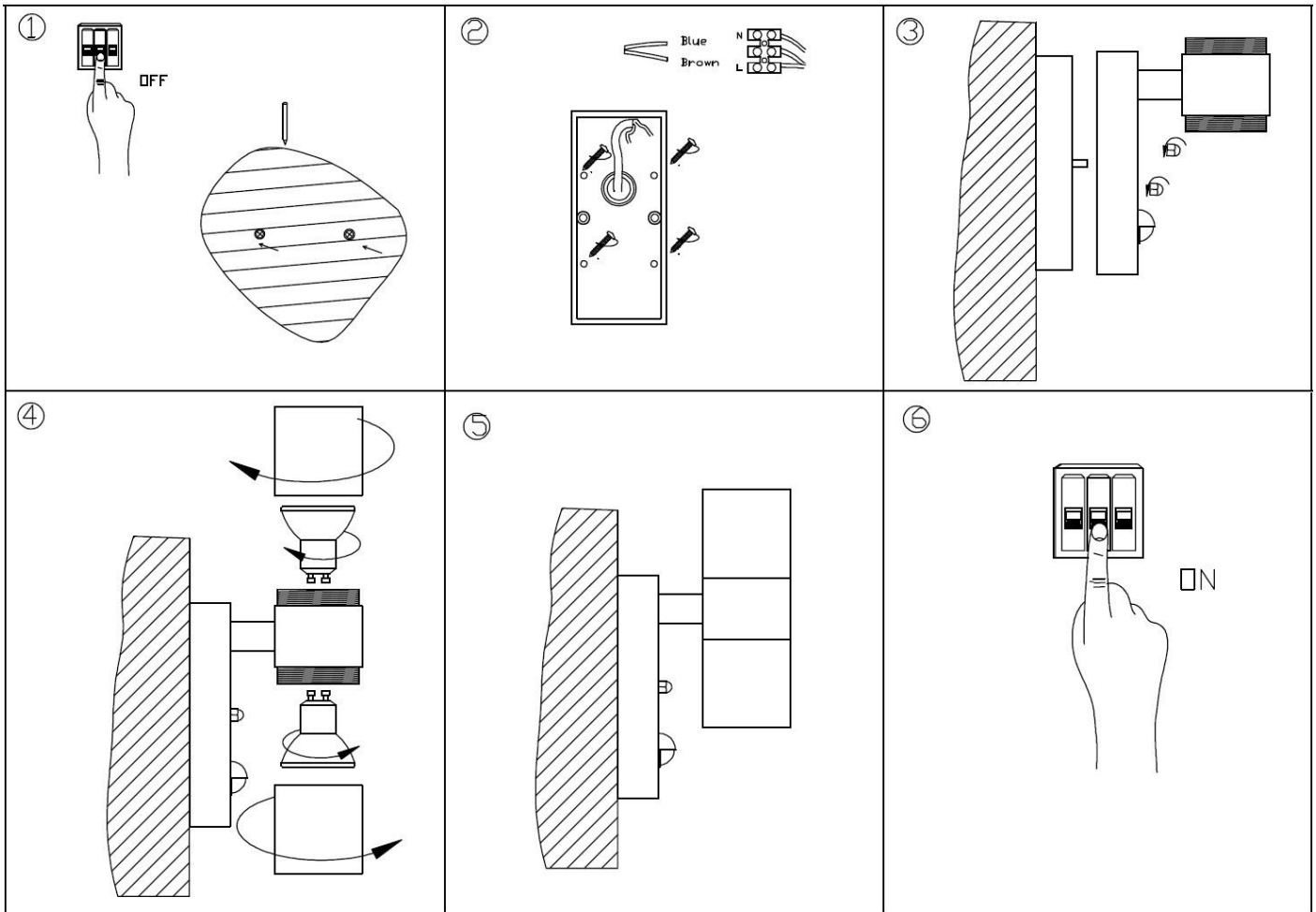

Sensor Settings

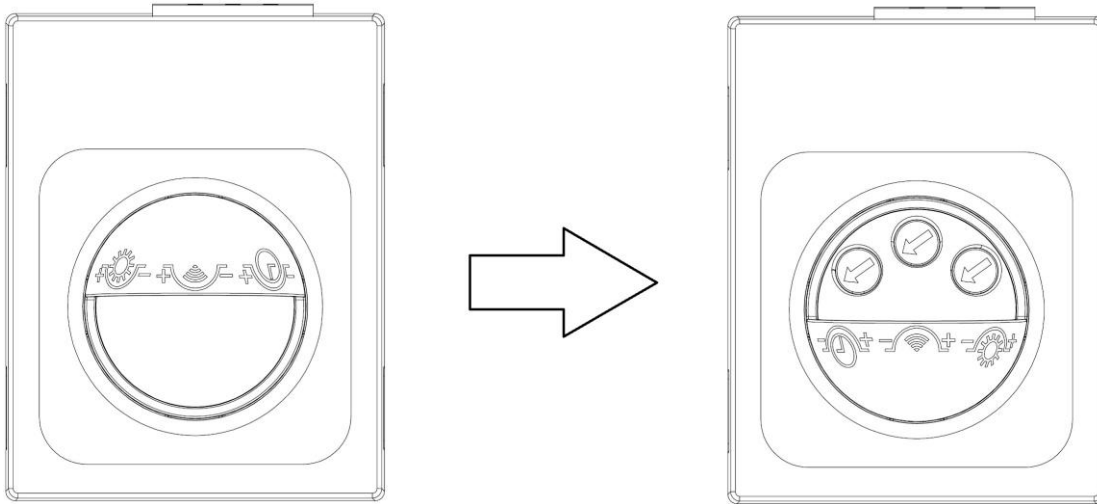

Rotate the cover above the sensor to locate the adjustment controllers.

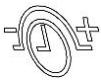
TIME:  The duration time of the luminaire remains ON can be adjusted.

The (+) position means the luminaire will be ON for the maximum duration time of 5 minutes.

The (-) position means the luminaire will be ON for the minimum duration time of 10 seconds.

NOTE: Once the PIR sensor has been triggered, any subsequent detection will start the timed period again from the beginning, the sensor will remain on until there is no movement detected.

DISTANCE:  The detection range of the sensor can be adjusted.

The (+) position means the sensor will detect any movement up to the maximum distance of 10m away.

The (-) position means the sensor will detect any movement up to the minimum distance of 0.5m away.

NOTE: The detection distance will depend on the height of installation of the luminaire and sensor.

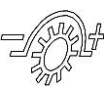
LUX:  The sensor has a built-in sensing device (photocell) that detects daylight and darkness.

The (+) position means that the sensor will work at both day and night. Maximum light of 2000lux.

The (-) position will only work at night. Minimum light of 10lux.

NOTE: If you want to test the detection area of the PIR sensor, please wait for the ambient light level is below 20lux.

Sensor Modes

AUTO MODE: Switch the power on, and the luminaire will be on for about 15 seconds. When it turns off, wait 5 seconds, and the luminaire will now be in the auto mode. Now, the luminaire will switch on and off automatically when it detects any movement.

MANUAL MODE: While in auto mode, switch the power OFF-ON-OFF-ON within 3 seconds (toggle ON/OFF 2 times within 3 seconds). The luminaire will enter manual mode and will be continuously on for 8 hours (manual mode). After 8 hours, the sensor will return to the auto mode.

RESET: To return the sensor to auto mode during the manual mode, turn the power OFF for 10 seconds and ON again. The luminaire will now be in auto mode.

Safety Tips

- Always ensure the power is OFF and the luminaire has cooled down before performing any maintenance, cleaning, changing the globes or making any adjustment to the luminaire.
- To avoid injury or damage to the luminaire, ensure that power leads and screws are secure before connecting the power.
- The luminaire must not be used if the protective shield or shade has been cracked or damaged. Replace the protective shield or shade before using the luminaire
- To clean, wipe with a soft damp cloth. Do NOT soak or immerse the luminaire in water or other liquids.
- Ensure that the luminaire does not come in contact with corrosive chemicals/solvents or abrasive cleaners etc.

Specifications

SKU #	246112
Rated Voltage	220-240V~ 50Hz
Rated Wattage	14W Max. (2x Max. 7W LED globes only)
Lamp Holder	GU10
Protection Class	Class II
IP Rating	IP44
Weight	0.3kg
Dimensions	H:210mm W:70mm E:120mm