

PILLAR LED FLOOR LAMP

SKU# 261455

Rated Voltage 12V DC 2A

Thank you for purchasing this quality Lucci product. To ensure correct function and safety, please read and follow all instructions carefully before assembly, installation and use of the product. Please keep the instructions for future reference.

Warranty

- This luminaire is covered by a 3-year warranty from the date of purchase. Please retain the proof of purchase.
- Warranty will be void if there is any damage due to improper usage or modification of the product.
- Failure to comply with the instructions in this manual may increase the risk of damage or injury and will void the warranty.

Installation Requirements

- Select a suitable location for this luminaire ;
 - Ensure it is on a flat and stable surface.
 - This product is suitable for indoor use only.
 - Do not place flammable material near or over the luminaire.
 - Ensure the luminaire is not installed in the direct line of an air vent/system.
 - If installing a luminaire in an area prone to moisture, ensure that the area is well ventilated, and an appropriately rated exhaust fan is used if required. Damage or corrosion caused by moisture is not a product fault, and as such is not covered under warranty.
- Take care not to pull any electrical wires during unpacking as this may damage the connection.
- Lay out all the components on a smooth surface and make sure no components are missing before assembling. If parts are missing, return the complete product to the place of purchase for inspection or replacement.
- Check whether the luminaire has been damaged during transport. Do not operate/install any product which appears damaged in any way. Return the complete product to the place of purchase for inspection, repair or replacement.
- Do not plug into the mains power socket-outlet before or during assembly. Only do so after the luminaire is fully assembled and ready to use for the first time.

Installation Directions

Remove all packaging material from the product.

1. Select a suitable location for the luminaire. See the installation requirements above.
2. Install the two legs (B & C) to the luminaire.
3. Tighten the screws (D) by the provided Allen key (E).
4. Connect the power adaptor (G) to the quick connector (F) then insert the power adaptor (G) into the mains socket outlet and ensure it is fully plugged in.

NOTE: Only use the power adaptor provided with the luminaire.

5. Turn the power on at the mains power socket outlet.

Refer to the section of 'Remote Control Operation' for details of the operation.

NOTE: The remote control is only effective if it is within 5M distance from the luminaire.

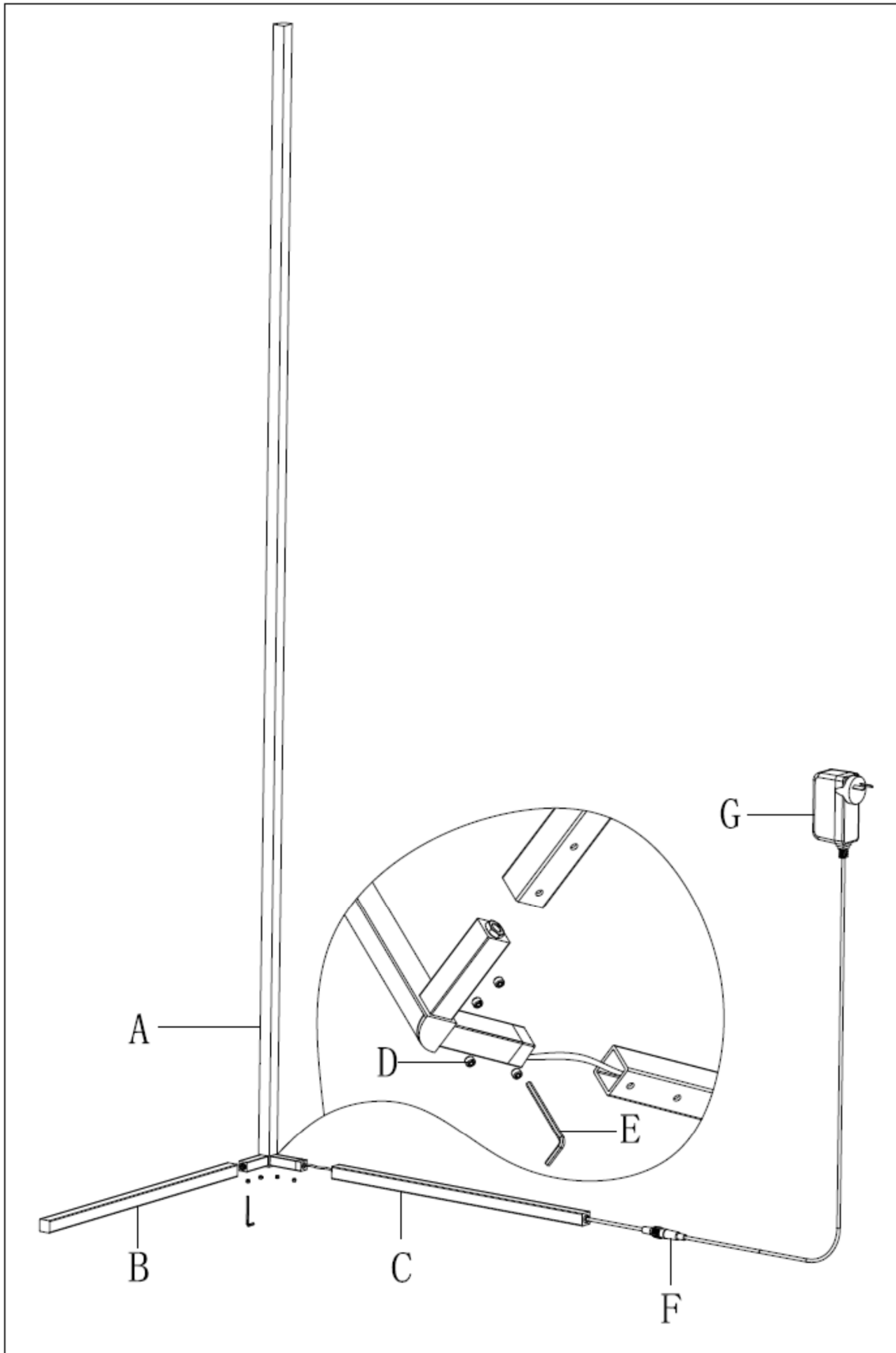

Remote control operation

ON/OFF	AUTO	SPEED UP	SPEED DOWN	MODE UP	MODE DOWN	BRIGHTNESS UP	BRIGHTNESS DOWN

MATCH	SETTING	RED	GREEN	BLUE	WHITE



NOTE: The remote control contains a CR2025 button battery. Refer to the ‘Battery tips and warning’ section for the details of safe use.

PAIR	For the use of the first time, press the pairing button 5 times, the luminaire will flash quickly and the remote will pair with the receiver. Press the pairing button 5 times again to unpair.
SETTING	The setting button is for setting the sequence of the colours. Press the setting button 5 times then enter the setting mode. Then press the colour button according to the sequence as required. Press the setting button again to exit the setting mode.
AUTO	Press the auto button, then the luminaire will enter the Auto mode. The colour of the luminaire will cycle in the set sequence.
Speed Up/Dn	Adjust the cycle speed of the colour.
Mode Up/Dn	Selection between different modes.
Brightness Up/Dn	Adjust the brightness of the luminaire.
R, G, B, W	Set to different colours.

Battery Tips and Warnings

- **WARNING – KEEP BATTERIES OUT OF REACH OF CHILDREN.**
- **CAUTION – Do not ingest battery—Chemical burn hazard.**
- If the coin/button cell battery is swallowed, it can cause severe internal burns in just 2 hours and can lead to death due to chemical burns and potential perforation of the oesophagus.
- If you think batteries might have been swallowed or placed inside any part of the body, seek immediate medical attention.
- If you suspect your child has swallowed or inserted a button battery, immediately call the 24-hour Poisons Information Centre on **13 11 26** for fast, expert advice.
- Regularly check the product and make sure the battery box lid is correctly secured. If the battery compartment does not close securely, stop using the product and keep it away from children.
- If the battery box lid has been cracked or damaged, do not continue to use this product.
- Dispose of used batteries immediately and safely (so they cannot be retrieved by children). Flat batteries can still be dangerous.
- Exhausted batteries are to be removed from the product.
- Keep new and used batteries away from children.
- Batteries shall only be installed or replaced by an adult. The battery box lid must be tightened after replacement.
- Ensure the batteries are inserted with the correct polarity.
- Remove batteries from the product when not in use for long periods.
- Dispose of used button batteries immediately and safely. Flat batteries can still be dangerous.

Safety Tips

- Always ensure the power is OFF and the luminaire has cooled down before performing any maintenance, cleaning or adjustment to the luminaire.
- To avoid injury or damage to the luminaire, ensure that power leads and screws are secure before connecting the power.
- **Young children should be supervised to ensure that they do not play with the portable lamp and its remote control.**
- The LEDs are not replaceable, and there are no serviceable parts, do not attempt to dismantle or open the product.
- Handle the luminaire with care to avoid any damage or breakage.
- Select a suitable location away from liquids and hazards.
- To clean, wipe with a soft damp cloth. Do NOT soak or immerse the product in water or other liquids.
- Ensure that the luminaire does not come in contact with corrosive chemicals/solvents or abrasive cleaners etc.

Specifications

SKU #	261455
Colour	Black
Rated Voltage	12V DC/2A (Power adaptor provided)
Rated Wattage	20W
LED Specs	Max.110 Lumens, RGB*, Dimmable* *Colour and brightness can be adjusted by remote control
Remote control	RF control, 5M control distance
Weight	1.2kg
Dimensions	H:1480mm L:415mm W:415mm